



**TROCAL**<sup>®</sup>  
That's my window.

# PremiLine – Sliding window/door system

# PremiLine – Your comfortable sliding system.



## » Quiet. Long lived. Safe.

There are many kinds of comfort. With PremiLine, the new, exceptionally quiet sliding system you'll learn a few more.

Comfort has many faces, for instance when a PremiLine sliding system is opened and closed. Its precision fits make it extremely quiet and easy to use.

Even with large glazed areas, the PremiLine profiles ensure that the sliding elements move in near perfect silence, a result of the window and door sashes' high stability.

Thanks to the excellent static properties of the underlying design, PremiLine sliding elements also provide a high level of security. And because PremiLine sliding elements also exhibit particularly long service lives, you can safely lean back and now enjoy more comfort when your PremiLine sliding elements run on high quality stainless steel tracks – Quiet. Long lived. Safe.

# Magnificent views to measure.



## »» PremiLine – open to many possibilities.

- **Design**  
Distinctive, double chamfered sash profiles with gaskets in black or light grey
- **Transparency**  
There are many possible glazing types to choose from. And of course, divided sliding elements can also be fitted with Georgian bars. Special functional glazing is possible with panes up to 28 mm thick.
- **Addition**  
On request a letterbox can be integrated in your PremiLine sliding door.
- **Matching look**  
Besides white, PremiLine is also available in laminated designs. You can choose between wood grain and plain colour on the outside – with neutral white on the inside – or wood grain on the outside and inside.

## »» Enjoy the best views

Whether wide or high – thanks to PremiLine profiles, also generous dimensions are now possible on sliding doors: the optimal frame for a magnificent view.

A sliding door is an important and style shaping element for your house and home. PremiLine profiles give sliding elements an appealing, distinctive look – thanks to the double chamfered sash profiles. The steel reinforcement and the aluminium reinforced centre section provide convincing static properties, also for the generous dimensioning of the sliding elements.

A range of frame casements are available for the various installation conditions. So you can enjoy the maximum freedom when dimensioning the height and width of your door.

Comfort to measure.



A practical addition:  
the integrated letterbox.



Some examples from the laminate colour range

**greenline**

Our greenline principle: that extra sustainability in the form of energy efficient window systems, lead free stabilisers in virgin material, and intelligent regrind concepts.

# A convincing design.

## » Many of the advantages presented by PremiLine elements are clear to see. Many, on the other hand, are in the detail.

The double chamfered sash profiles are responsible for the distinctive design. In addition, the profiles are compatible with all 70 mm standard window systems. A further advantage lies in the profile's structure: the outer frame can be either welded or secured mechanically on site. When particularly large sliding door systems are to be installed, the elements can then be transported easily through confined stairwells.

The highest quality and the perfect interaction of all components are the most important conditions for the optimal overall design. These are good reasons in favour of the technical details presented by the PremiLine elements.



Profile corners also with straight connections

Thanks to rollers of special rigid PVC, the system promises exceptional quiet running and ease of operation.

Tracks of high quality stainless steel for maximum service life

## » A flexible system

PremiLine elements also exhibit convincing versatility. This flexible system allows the most diverse opening modes.

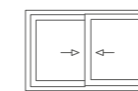

Sliding window with two sliding sashes

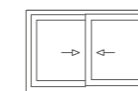

Sliding window with two sliding sashes and fixed glazing unit

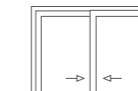

Two-part element with two sliding sashes

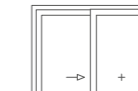

Two-part element with sliding door and glazing unit

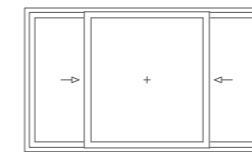

Three-part element with two sliding sashes and central fixed glazing unit

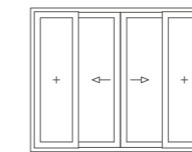

Four-part element with two sliding sashes and two fixed glazing units

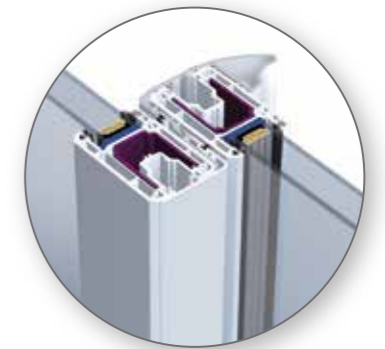

The aluminium reinforced centre section with full-length handle provides a high degree of stability, reliability, and tightness.

## » This structure and the good static properties present many advantages:

- **Versatility**  
Sliding windows and sliding doors can be offered in two, three, or four part designs
- **Precision**  
Minimum wearing for ease of operation, quiet running, and long service life
- **Stability**  
Large glazed areas possible with aluminium reinforced centre section with full-length handle
- **Individuality**  
A range of frame casements for various installation conditions
- **Flexibility**  
Outer frames can be welded or connected mechanically

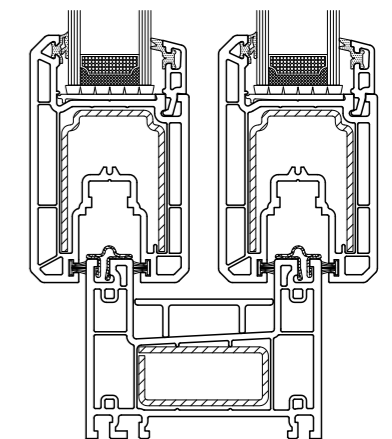

The PremiLine profile is a three chamber design with a construction depth of 80 mm in the frame and 54 mm in the sash.

**profine GmbH**

TROCAL Profile Systems

53840 Troisdorf

Phone: +49 2241 9953-0

Fax: +49 2241 9953-3561

Internet: [www.trocal-profile.com](http://www.trocal-profile.com)

E-mail: [info@trocal-profile.com](mailto:info@trocal-profile.com)



**TROCAL®**  
That's my window.